

APPROVAL SHEET

Customer:	
Description:	MEMS Microphone
Model:	CMM3526DL-098H64S261
Customer P/N:	

Issued by	Checked by	Appoved by	Customer

HUNSTON ELECTRONICS LIMITED

Website: hunston.com.hk
Email: sales@hunston.com.hk
Tel: +852 3591 1490
Fax: +852 3591 1491

1. ABSOLUTE MAXIMUM RATINGS

Parameter	Absolute Maximum Rating	Units
V _{DD} , DATA to Ground	-0.3 , +5.0	V
CLOCK to Ground	-0.3 , +5.0	V
SELECT to Ground	-0.3 , +5.0	V
Input Current	±5	mA
Short Circuit Current to/from DATA	Indefinite to Ground or V _{DD}	sec
Temperature Range	-40 to +100	°C

Stresses exceeding these “Absolute Maximum Ratings” may cause permanent damage to the device. These are Stress ratings only. Functional operation at these or any other conditions beyond those indicated under “Acoustic & Electrical Specification” is not implied. Exposure beyond those indicated under “Acoustic & Electrical Specification” for extended periods may affect device reliability.

2. ACOUSTIC & ELECTRICAL SPECIFICATIONS

TEST CONDITIONS: 23±2 °C, 55 ± 20% R.H., V_{DD}=1.8V, f_{CLOCK}=2.4MHz, SELECT pin grounded, no load, unless Otherwise indicated

General Microphone Specifications

Parameter		Symbol	conditions	Min	Typ	Max	unit
Supply Voltage		V _{DD}		1.62	-	3.6	V
Clock Frequency Range	Sleep Mode			0		250	kHz
	Low-Power Mode			351		800	kHz
	Standard Performance Mode			1.024		2.475	MHz
				3.072		4.8	
Sleep Current		I _{SLEEP}	f _{CLOCK} ≤ 250 kHz	-	80		μA
DC Output			Full scale = ±100	-	0	-	% FS
Directivity				Omnidirectional			
Polarity			Increasing sound	Increasing density of 1's			
Data Format				½ Cycle PDM			
Short Circuit Current		I _{SC}	Grounded DATA pin	1	-	20	mA
Output Load		C _{LOAD}		-	-	140	pF
Fall-asleep Time			f _{CLOCK} ≤ 250 kHz	-	-	10	ms
Wake-up Time			f _{CLOCK} ≥ 351 kHz	-	-	15	ms
Power-up Time			V _{DD} ≥ V(min)	-	-	50	ms
Mode-Change Time				-	-	10	ms

Standard Performance Mode

TEST CONDITIONS: $f_{\text{clock}} = 2.4\text{MHz}$, $V_{\text{DD}} = 1.8\text{V}$, unless otherwise indicated

Parameter	Symbol	conditions	Min	Typ	Max	unit
Supply Current	I _{DD}	$f_{\text{clock}} = 2.4\text{MHz}$	-	800	950	μA
Sensitivity	S	94 dB SPL @ 1kHz	-27	-26	-25	dBFS
Signal to Noise Ratio	SNR	94 dB SPL@ 1kHz, A-weighted, $f_{\text{clock}} = 2.4\text{MHz}$	-	64.3	-	dB(A)
Total Harmonic Distortion	THD	94 dB SPL @ 1kHz, S = Typ	-	0.2	-	%
Acoustic Overload Point	AOP	10% THD @ 1kHz, S = Typ	-	120	-	dB SPL
Power Supply Rejection Ratio	PSRR	200 mV _{pp} sinewave @ 1kHz	-	55	-	dBV/FS
Power Supply Rejection	PSR+N	100 mV _{pp} square wave @ 217 Hz, A-weighted	-	-84	-	dBFS (A)

Low-Power Mode

TEST CONDITIONS: $f_{\text{clock}} = 768\text{kHz}$, $V_{\text{DD}} = 1.8\text{V}$, unless otherwise indicated

Parameter	Symbol	conditions	Min	Typ	Max	unit
Supply Current	I _{DD}	$f_{\text{clock}} = 768\text{Hz}$	-	300	350	μA
Sensitivity	S	94 dB SPL @ 1kHz	-27	-26	-25	dBFS
Signal to Noise Ratio	SNR	94 dB SPL@ 1kHz, A-weighted, $f_{\text{clock}} = 2.4\text{MHz}$	-	64	-	dB(A)
Total Harmonic Distortion	THD	94 dB SPL @ 1kHz, S = Typ	-	0.2	-	%
Acoustic Overload Point	AOP	10% THD @ 1kHz, S = Typ	-	120	-	dB SPL
Power Supply Rejection Ratio	PSRR	200 mV _{pp} sinewave @ 1kHz	-	59	-	dBV/FS
Power Supply Rejection	PSR+N	100 mV _{pp} square wave @ 217 Hz, A-weighted	-	-86	-	dBFS (A)

Microphone Interface Specifications

Parameter	Symbol	conditions	Min	Typ	Max	unit
Logic Input High	V_{IH}		$0.65 \times V_{DD}$	-	$V_{DD} + 0.3$	V
Logic Input Low	V_{IL}		-0.3	-	$0.35 \times V_{DD}$	V
Logic Output High	V_{OH}	$I_{OUT} = 2\text{mA}$	$V_{DD} - 0.45$	-	-	V
Logic Output Low	V_{OL}	$I_{OUT} = 2\text{mA}$	-	-	0.45	V
Clock Duty Cycle		$1\text{MHz} \leq f_{CLOCK} \leq 4.8\text{MHz}$	40	-	60	%
Clock Rise/Fall Time	t_{EDGE}		-	-	15	ns
Delay Time for Data Assertion	t_{DD}		18	28	40	ns
Delay Time for High Z	t_{DZ}		3	-	16	ns

3. MICROPHONE STATE DIAGRAM

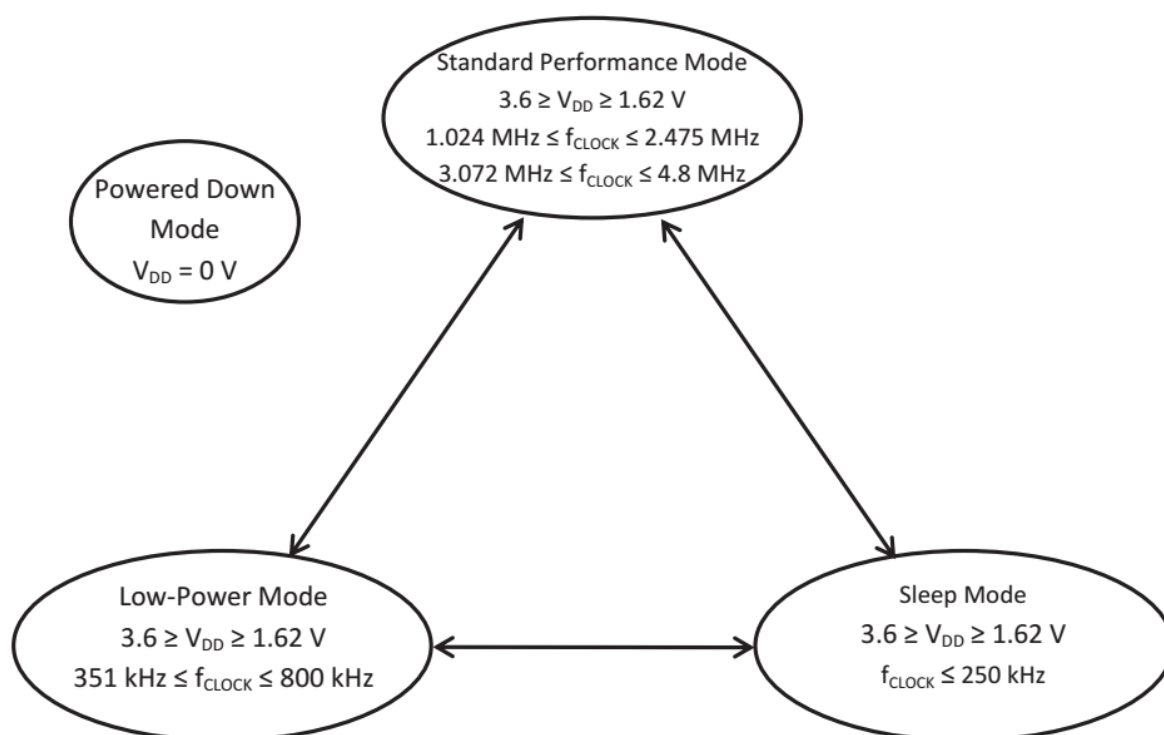

4. FREQUENCY RESPONSE CURVE

Typical Free Field Response
Normalized to 1 kHz
CLK=2.4MHz VDD=1.8V

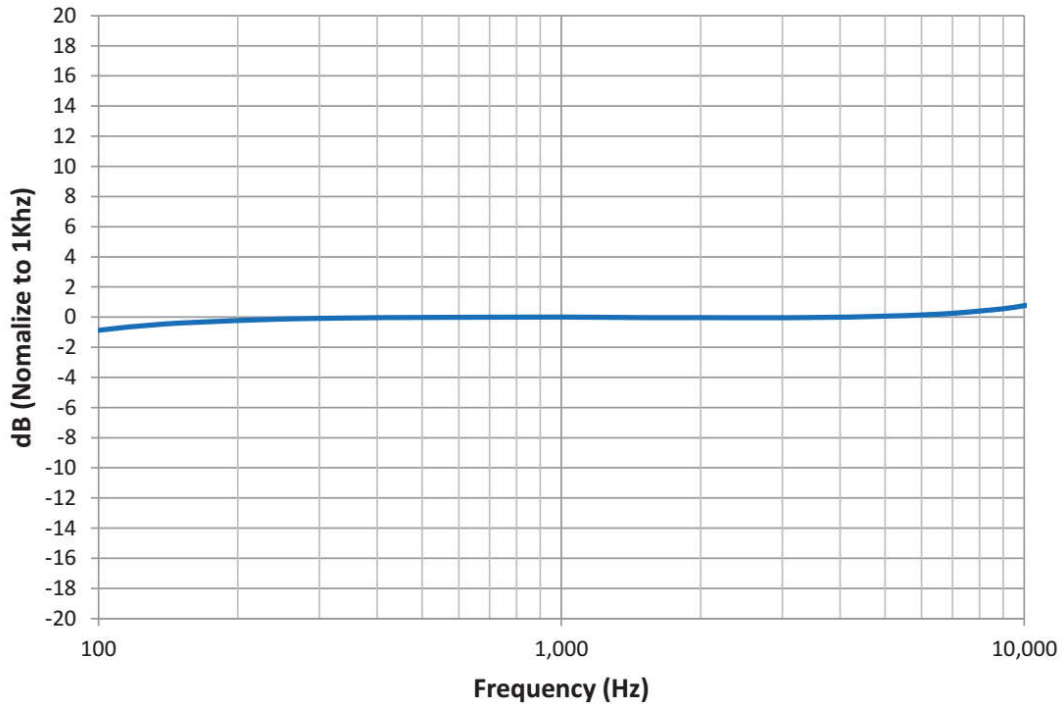

5. INTERFACE CIRCUIT

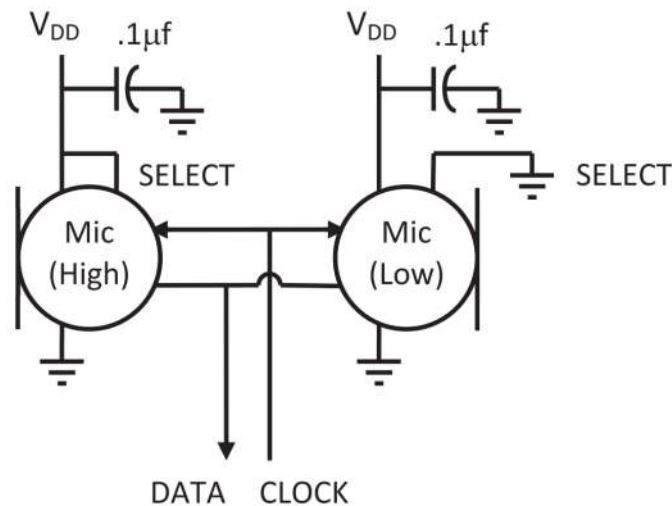

Microphone	SELECT	Asserts DATA On	Latch DATA On
Mic(High)	V _{DD}	Rising Clock Edge	Falling Clock Edge
Mic(Low)	GND	Falling Clock Edge	Rising Clock Edge

Note: Bypass capacitors near each Mic VDD PIN are recommended to provide maximum SNR performance. It should not contain Class 2 dielectrics.

6. TIMING DIAGRAM

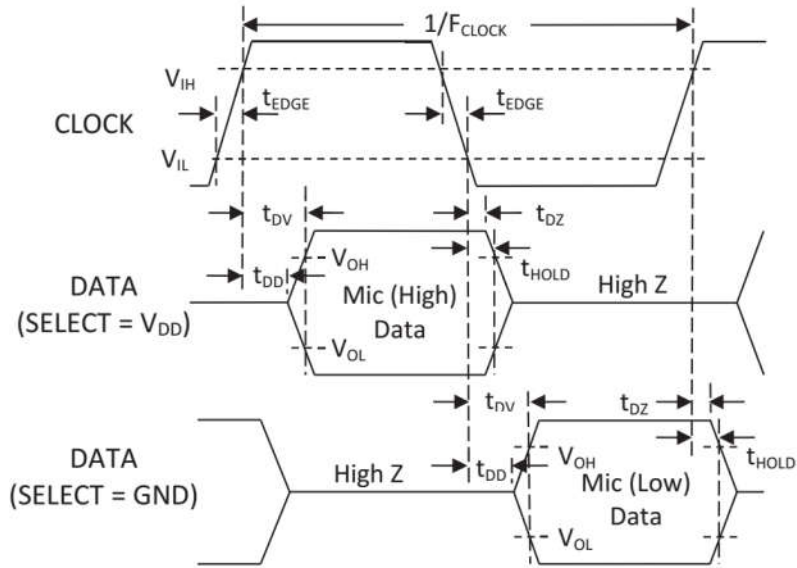

7. MECHANICAL SPECIFI

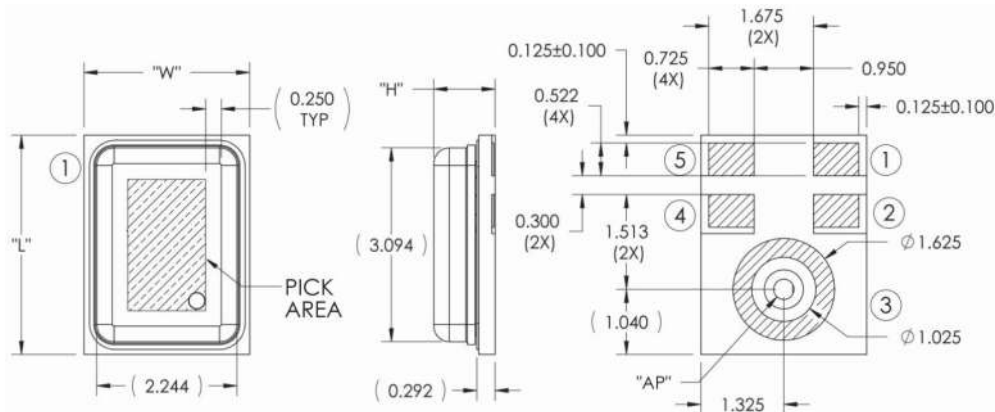

Item	Dimension	Tolerance
Length (L)	3.50	± 0.1
Width (W)	2.65	± 0.1
Height (H)	0.98	± 0.1
Acoustic Port (AP)	$\text{Ø}0.325$	± 0.05

Pin#	Pin Name	Type	Description
1	DATA	Digital O	PDM Output
2	SELECT	Digital I	Lo/Hi (L/R) Select This pin is internally pulled low but should not be left floating.
3	GROUND	Power	Ground
4	CLOCK	Digital I	Clock Input
5	V_{DD}	Power	Power Supply

Notes: Pick Area only extends to 0.25 mm of any edge or hole unless otherwise specified.
 Dimensions are in millimeters unless otherwise specified.
 Tolerance is ± 0.15 mm unless otherwise specified

8. EXAMPLE LAND PATTERN

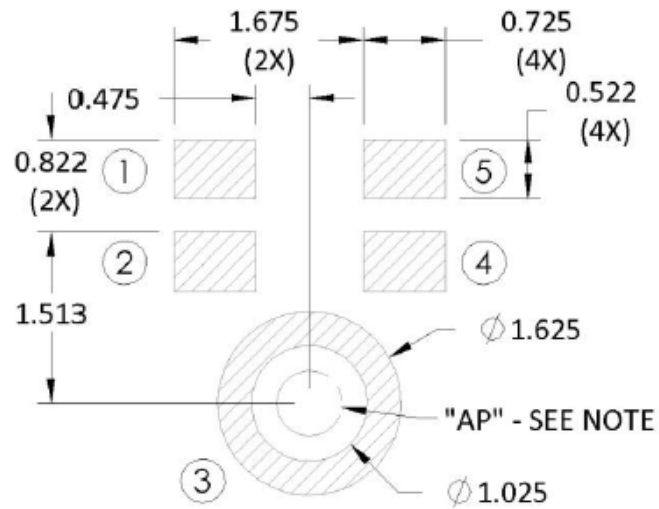

9. EXAMPLE SOLDER STENCIL PATTERN

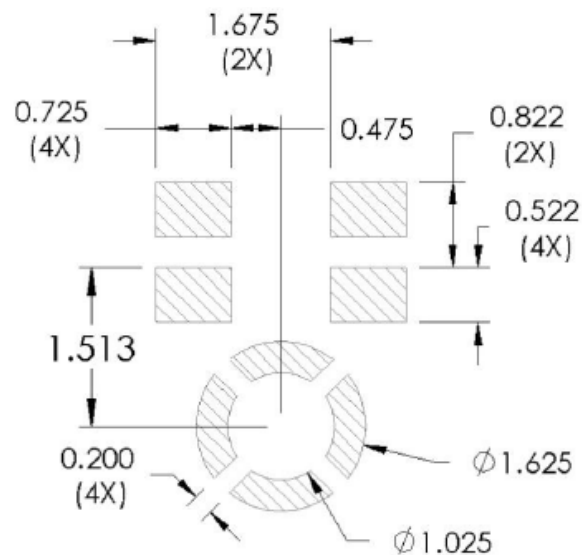

Notes: Dimensions are in millimeters unless otherwise specified.
Further optimizations based on application should be performed.

10. PACKAGING & MARKING DETAIL

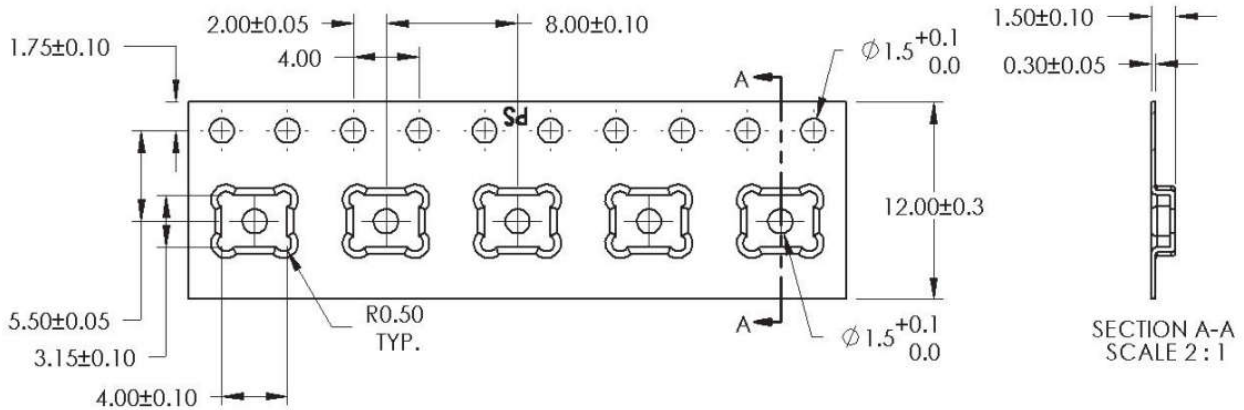

Model Number	Suffix	Reel Diameter	Quantity Per Reel
CMM3526DL-098H64S263	-8	13"	5,000

Notes: Dimensions are in millimeters unless otherwise specified.

Vacuum pickup only in the pick area indicated in Mechanical Specifications.

Tape & reel per EIA-481.

Labels applied directly to reel and external package.

Shelf life: Twelve (12) months when devices are to be stored in factory supplied, unopened ESD moisture sensitive bag under maximum environmental conditions of 30°C, 70% R.H.

11. RECOMMENDED REFLOW PROFILE

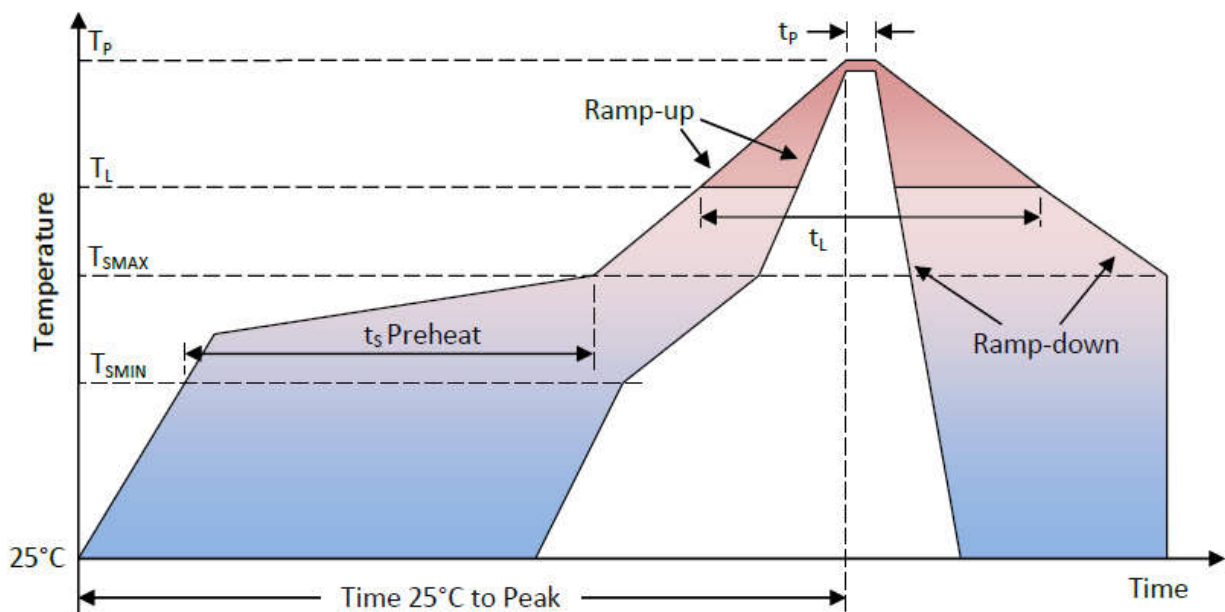

Profile Feature	Pb-Free
Average Ramp-up rate (T_{SMAX} to T_P)	3°C/second max.
Preheat <ul style="list-style-type: none"> • Temperature Min (T_{SMIN}) • Temperature Max (T_{SMAX}) • Time (T_{SMIN} to T_{SMAX}) (t_s) 	150°C 200°C 60-180 seconds
Time maintained above: <ul style="list-style-type: none"> • Temperature (T_L) • Time (t_L) 	217°C 60-150 seconds
Peak Temperature (T_P)	260°C
Time within 5°C of actual Peak Temperature (t_p)	20-40 seconds
Ramp-down rate (T_P to T_{SMAX})	6°C/second max
Time 25°C to Peak Temperature	8 minutes max

Notes: Based on IPC/JDEC J-STD-020 Revision C.

All temperatures refer to topside of the package, measured on the package body surface.

12. ADDITIONAL NOTES

(A)MSL (moisture sensitivity level) Class 1.

(B) Maximum of 3 reflow cycles is recommended.

(C) In order to minimize device damage:

- Do not board wash or clean after the reflow process.
- Do not brush board with or without solvents after the reflow process.
- Do not directly expose to ultrasonic processing, welding, or cleaning.
- Do not insert any object in port hole of device at any time.
- Do not apply over 30 psi of air pressure into the port hole.
- Do not pull a vacuum over port hole of the microphone.
- Do not apply a vacuum when repacking into sealed bags at a rate faster than 0.5 atm/sec.

13. MATERIALS STATEMENT

Meets the requirements of the European RoHS directive 2011/65/EC as amended.

Meets the requirements of the industry standard IEC 61249-2-21:2003 for Halogenated substances and XFT Green Materials Standards Policy section on Halogen-Free.

Ozone depleting substances are not used in the product or the processes used to make the product, including compounds listed in Annex A, B, and C of the "Montreal Protocol on Substances That Deplete the Ozone Layer."

14. RELIABILITY SPECIFICATIONS

Test	Description
Thermal Shock	100 cycles air-to-air thermal shock from -40°C to +125°C with 15 Minute soaks. (IEC 68-2-4)
High Temperature Storage	1,000 hours at +105°C environment (IEC 68-2-2 test Ba)
Low Temperature Storage	1,000 hours at -40°C environment (IEC 68-2-2 test Aa)
High Temperature Bias	1,000 hours at +105°C under bias (IEC 68-2-2 test Ba)
Low Temperature Bias	1,000 hours at -40°C under bias (IEC 68-2-2 test Aa)
Temperature / Humidity Bias	1,000 hours at +85°C /85% R.H. under bias .(JESD22-A101A-B)
Vibration	4 cycles of 20 to 2,000 Hz sinusoidal sweep with 20 G peak acceleration lasting 12 minutes in X, Y, and Z directions. (Mil-Std-883E, method 2007.2 A)
ESD-LID/GND	3 discharges of ± 8 kV direct contact to lid while unit is grounded. (IEC 61000-4-2)
ESD-MM	3 discharges of ± 200 V direct contact to I/O pins. (ESD STM5.2)
Reflow	5 reflow cycles with peak temperature of +260°C
Mechanical Shock	3 pulses of 10,000 G in the X, Y, and Z direction (IEC 68-2-27, Test Ea)

Note: After reliability tests are performed, the sensitivity of the microphones shall not deviate more than 3 dB from its initial value.

After 3 reflow cycles, the sensitivity of the microphones shall not deviate more than 1 dB from its initial value.